

**RENDERS 3-AXLED CONTAINER CHASSIS - EXTENDABLE AT REAR
WITH STRAIGHT NECK **TYPE EURO 920RN******WEIGHTS**

Fifth wheel pressure: 16 tons

Axles pressure: 27 tons

Total mass: 43 tons

KING PIN

2 "kingpin with 1 position

DIMENSIONS

Total length extended ± 13.309 mm

Total length retracted $\pm 11,045$ mm

Width on back frame ± 2.480 mm

Fifth wheel height at front: ± 1.050 mm unloaded

(Height 9.6ft HC container = 2.920 mm total)

Total height unloaded ± 4.060 mm (theoretical), in practice ± 4.050 mm

Total height loaded ± 4.020 mm (± 30 lowering on tires-suspension)

MAIN BEAMS

In high-quality steel

Straight neck height 100 mm reinforced including coupling plate

For straight neck height without 20ft central position 90 mm (= Type EURO 900RN)

Beam height behind 400 mm

Necessary chassis adjustments and cross connections

Necessary reinforcements for axle suspension and accessories

Hufferproof rear side

Reinforced container arms and chassis construction

MAIN BEAMS CENTER

1.300 mm above axle set (center-center)

SAF AXLES AND SUSPENSION

3 x 9 ton axles / disc \varnothing 430 mm / 120 mm offset / standard air suspension

Distance between axles:

1.410 mm between 1st and 2nd axle

1.310 mm between the 2nd and 3rd axle

Manual lift axle on 1st axle

(little space under tire - if requested more space, then need mount 385/55R 22.5 tires)

TIRES AND RIMS - BRIDGESTONE BRAND (or A-brand choice by constructor)

6x 385/65 R22.5 / offset 120 mm

10-holes steel rims / color silver

MUDGUARDS

6x PVC mudguards with ex-spray mud flap attached with steel brackets

LANDING LEGS JOST

With S-foot, can be operated on one side with 2 rotating speeds

BRAKE AND AIR SYSTEM - BRAND WABCO

ABS / EBS 2S2M with RSS function

120 liter steel air tanks for brake and air suspension

With pneumatic parking brake

1x yellow / 1x red coupling hand

1x lifting and lowering valve (5 positions)

ELECTRICITY IN ADR BRAND ASPÖCK

connected conform EU norm

conform with ADR regulations AT - FL

ELECTRICITY AT FRONT

2x 7-poled plug

1x 15-poled plug

1x EBS plug

LIGHTING ASPÖCK

2x multifunction rear lights ECO POINT II or EUROPOINT III (choice customer)

2x4 Orange sidelights

Width lights at rear

License plate light

White reflecting contour marking side conform EU-norm

Red reflecting contour marking rear conform EU-norm

Conform ADR regulations AT-FL

SLIDING TABLE REAR

Operated by pneumatic cylinder with stainless steel rods and associated control valve with mechanical locking for desired container position.

CONTAINER POSITIONS

1x 45ft container (2.5 ft overhang container: not legal, if more 45ft transport: EURO 925RN)
2x 20ft container
1x 20ft container central
1x 30ft container at rear
1x 20ft container at rear
1x 40ft HC or 40ft ISO container
Reinforced container arms

STANDARD ACCESSORIES INCLUDED

Closed foldable aluminum side protection conform EU standard.
Side protection board can be folded 90 °
2x square LED work lamps integrated in rear side
2x PVC yellow wheel chocks
1x PVC document holder (cylinder)
1x foldable ADR plate
2x Ferry rings front + 2x Ferry eyes rear
Necessary side and rear markings according to EU norm

CONSERVATION (galva execution possible as option except for rear frame and side protection)

Steel-blasted according to 2.5 SAE norm
Chemically degreased and cleaned
1x hy-zinc
2x epoxy primer
2x top coating layer in RAL color

WARRANTY TERMS

- 2 years on construction and specification of Renders chassis and chassis parts.
- 2 years on purchased parts according to the warranty conditions suppliers (WABCO, ASPOCK...)
- 2 years on paintwork conform instructions PPG or BASF, except for container tangent surfaces, movable parts and locking positions

DELIVERY TERMS

After consultation and in regard to the production time available at moment of your order decision.

An extremely user-friendly and multifunctional container chassis completely "Hufterproof" very rigidly built to contemporary legal norms with a long lifespan based on Renders' years of experience and knowledge.

EURO 900 RN
EURO 920 RN
EURO 925 RN

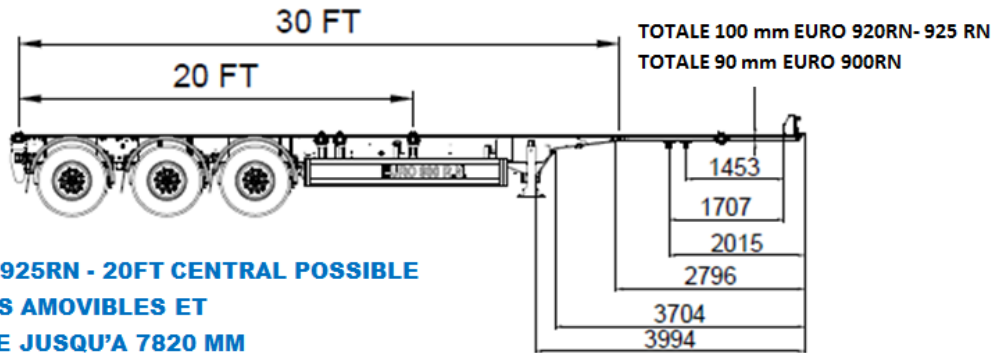

EURO 920RN - EURO 925RN - 20FT CENTRAL POSSIBLE
POUR ISO ET CAISSES AMOVIBLES ET
CONTENEUR CITERNE JUSQU'A 7820 MM

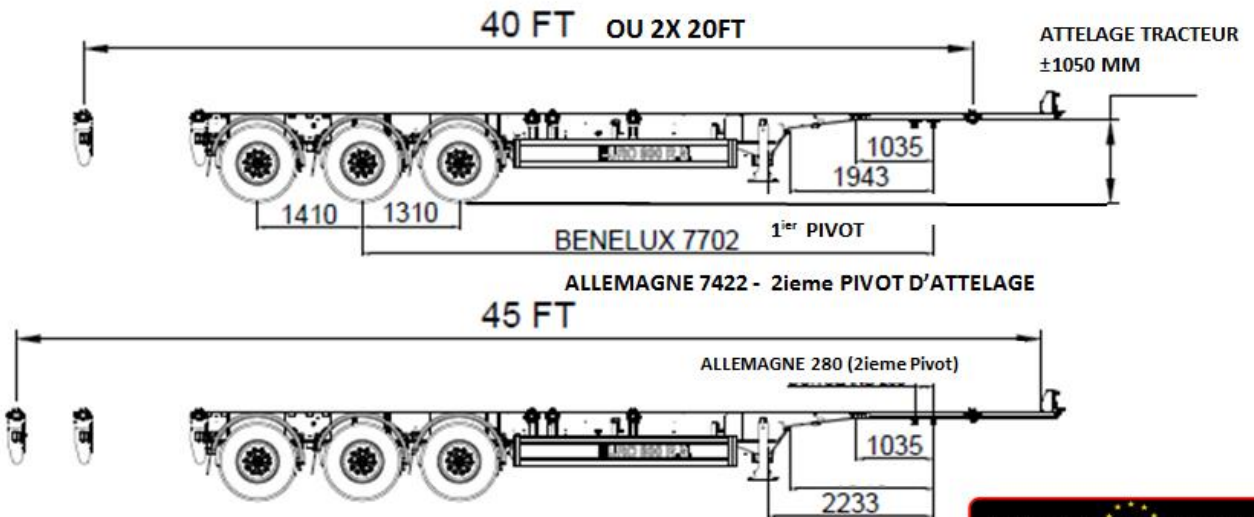

RENDERS TRAILERS NV