

**RENDERS 3-AXLED CONTAINER CHASSIS – FIXED 45 FT EXECUTION
TYPE EURO 100****WEIGHTS**

Coupling pressure: 16 tons
Axle load: 27 tons
Total mass: 43 tons

KING PIN

2 "kingpin with 1 position at 1,620 mm

DIMENSIONS

Total length of unladen chassis ± 13,400 mm
Total length chassis loaded with 45Ft container: ± 13,970 mm
Width ± 2.480 mm
Coupling height 1,170 mm with 385/65 R22.5 tires (depending on fifth wheel height tractor)
Coupling height 1,150 mm with 385/55 R22.5 tires (depending on tractor fifth wheel height)

WHEELBASE

kingpin to center axis 7,800 mm
From kingpin to rear frame 11,780 mm.

CHASSIS FRAME

High-quality steel S 700 MC
Chassis frame with gooseneck, reinforced version
Renders standard "vandal-hufter proof" rear frame
Main beam height 400 mm
Neck height 130 mm (16 tons)
Gooseneck neck length 3,850 mm (for 45FT tunnel)

SAF AXLES AND SUSPENSION

3 x 9 ton axles / disc Ø 430 mm / 120 mm offset / standard air suspension
Distance between the axes:
1,410 mm between 1st and 2nd axis
1,310 mm between 2nd and 3rd axis
No axle lift provided: optional (see options on last page)

TIRES AND RIMS - BRIDGESTONE BRAND (or manufacturer choice A-brand)

6x 385/65 R22.5 / 120 mm offset
10-hole steel rims / color silver

MUDGUARDS

6 PVC mudguards with galvanized steel holders and exspray mud flap

LANDING LEGS JOST

24 tons - 2 rotation speeds - with S-foot

BRAKE AND AIR SYSTEM - BRAND WABCO

ABS / EBS 2S2M with RSS function

2x80 liter steel air tanks for brake and air suspension

With pneumatic parking brake

1x yellow / 1x red coupling hand

1x lift and lower valve (5 positions)

ELECTRICITY IN ADR - BRAND ASPÖCK

Wiring, lamps, sockets in accordance with ADR regulations AT - FL

Connected in accordance with EU standard

ELECTRICITY FRONT

2x 7-pin plug

1x 15-pin plug

1x EBS plug

Plugs mounted on a Vandal-Hufter proof raised sturdy front panel

ASPÖCK LIGHTING

2x multi-function rear lights LED type EUROPOINT III

4x orange side lights

Width rear lights

License plate lighting

White contour marking laterally in accordance with EU standard

Red contour marking at the back in accordance with EU standard

in accordance with ADR regulations AT - FL

CONTAINER POSITIONS

1x 45ft HC with tunnel version on 42.5FT connection. (Tunnel 3,850 mm)

STANDARD ACCESSORIES

Foldable closed aluminum side protection painted in RAL color

2 PVC yellow wheel chocks

1 PVC document holder

2 square LED work lights mounted at the back

2 Ferry rings in the front and 2 Ferry eyes in the back (A581 standard)

CONSERVATION

Blank steel blasted according to 2.5 SAE standard.

Chemically degreased and cleaned

1x Hy-zinc

2x epoxy primer

2x paint layer in standard RAL color

WARRANTY CONDITIONS

- 2 years on construction and execution on Renders chassis and chassis parts
- 2 years on parts purchase according to warranty conditions from suppliers (Wabco, Aspöck ...)
- 2 years of paintwork according to PPG instructions, except for interfaces of containers, movable parts and locking positions are excluded.

DELIVERY PERIOD

In mutual consultation and depending on production planning at the time of your order decision.

An extremely user-friendly 45FT container chassis, completely "Hufterproof", very solidly built according to contemporary legal standards with a long lifespan based on years of experience and knowledge of Renders.

+/- 13970 mm Total length containerchassis (loaded with 45Ft container)

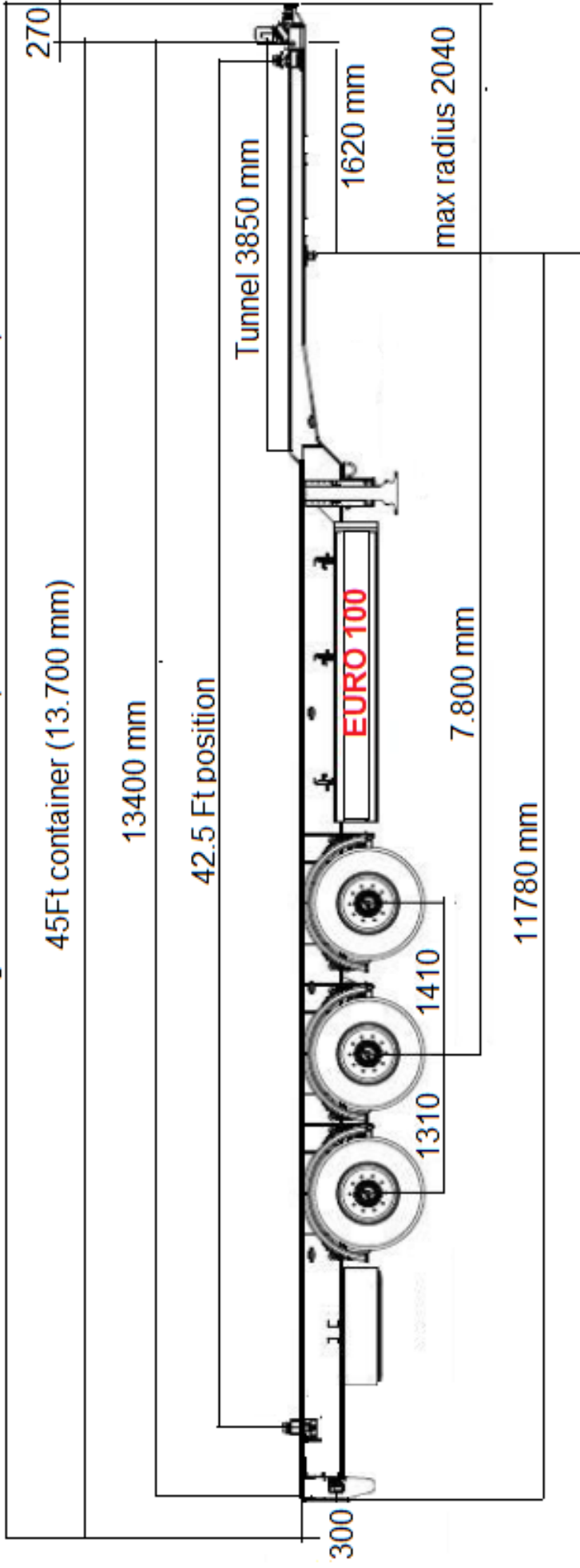

RENDERS TRAILERS NV

EURO 100